

Elite II Pro Series Manual Presses

www.ranar.com

Features:

- Adjustable Spring Tension System
- XL Screen Capacity 25" Wide
- Cast Aluminum Micro Registration
- Micro Adjust X-Y-Z Movement
- Steel Index Key & Roller Bearing Registration
- Easy Tools Free Adjustments
- Extruded Aluminum Back Clamp
- Off Contact Adjustment
- Uneven Screen Adjustment
- Smooth Bearing Rotation
- Tubular Print Stations
- Print Station Locator
- Heavy Duty Tubular Stand
- Never Warp Aluminum Platens
- Platen Location Ruler
- Quick Change Platens

*Aluminum
Platens
Included*

E-6600

The professional Elite Series II Screen Printing Presses are proven workhorses.

They are designed for heavy duty use with a 25" screen frame capacity, and come loaded with many features that would be an asset in any screen printing shop. Easy and fast setup of multi color screen printed designs. Tool free adjustments for lift spring tension, micro registration, screen angle, off contact, and platen leveling. Each print head has warp screen adjustment. A steel key glides into 2 roller bearings which hold perfect registration from color to color.



Tools Free
Micro Adjust
Print Head



Off Contact / Adjustment



Station Arm Leveling

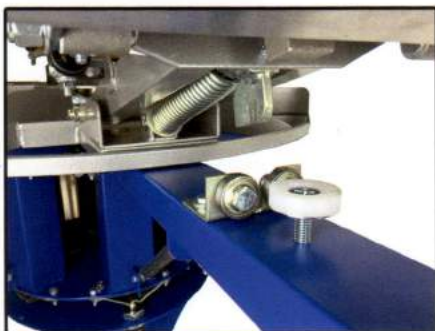

Roller Bearings & Steel Key for Perfect Registration

OPTIONS

- Side Clamps
- Automatic Press Quick Release Pallet Bracket
- Number and Hat Printing Attachments
- Ranar Accesories and Pallets Available



149 Lomita St, El Segundo, CA 90245
 US & Canada: (800) 421-9910
 PH: (310)414-4122, FX: (310)414-4133
 Email: sales@ranar.com

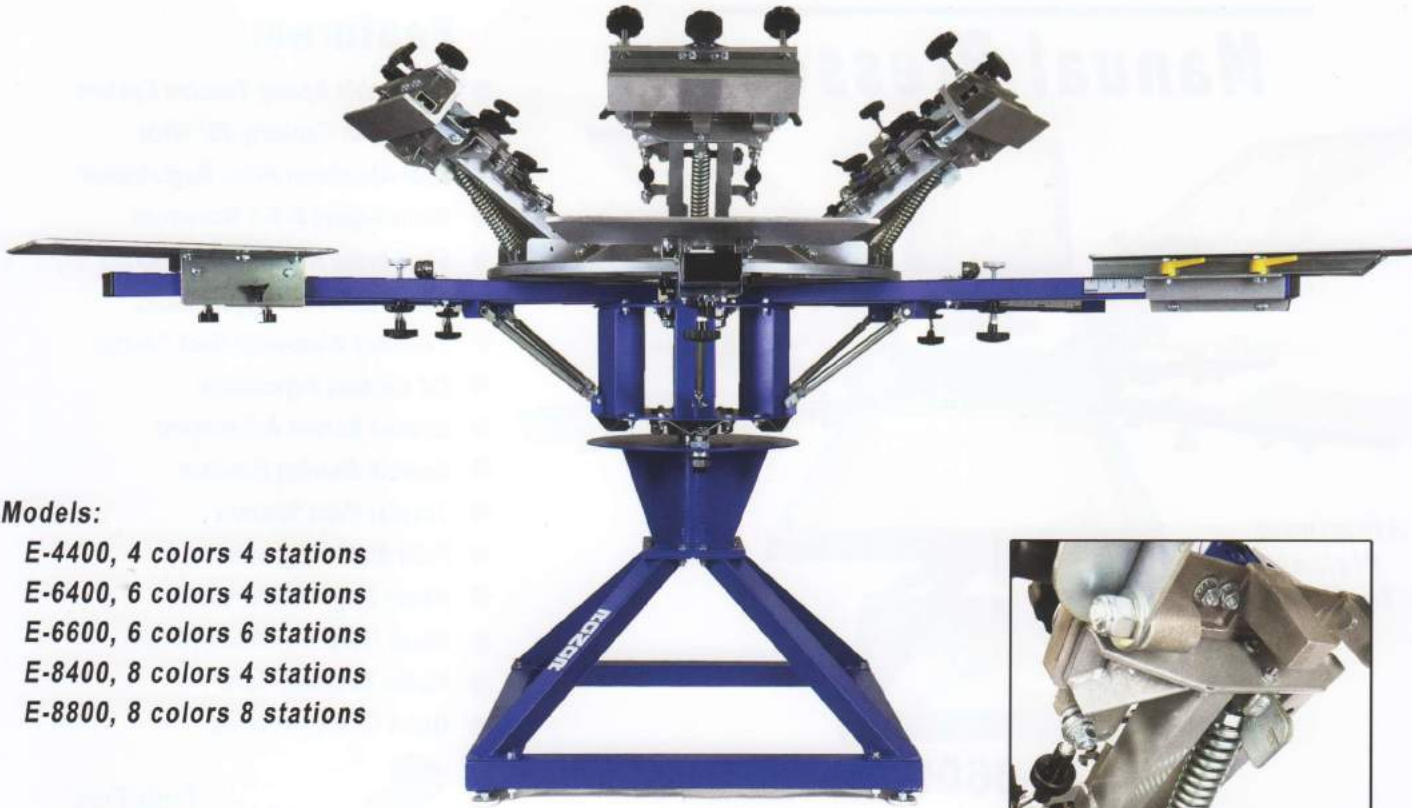

Models:

- E-4400, 4 colors 4 stations
- E-6400, 6 colors 4 stations
- E-6600, 6 colors 6 stations
- E-8400, 8 colors 4 stations
- E-8800, 8 colors 8 stations

The Elite Series II Presses are manufactured in the USA from the finest quality materials. All sheet metal parts are punched with a CNC turret punch press, and then formed to close tolerances. All tubular steel parts are welded using jigs to ensure consistency. Our aluminum parts are precision machined to close tolerances. The screen back clamp is extruded aluminum for strength with minimal deflection. All parts have powder coated finishes and are assembled by hand to ensure easy set up of the press, increased production and a trouble free work life.



Adjustable compression spring

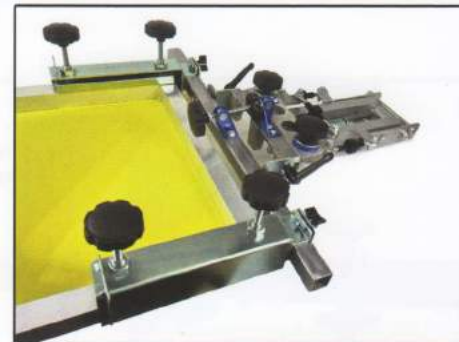

Side clamp lift arm

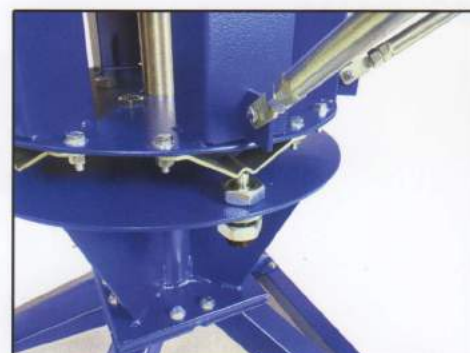
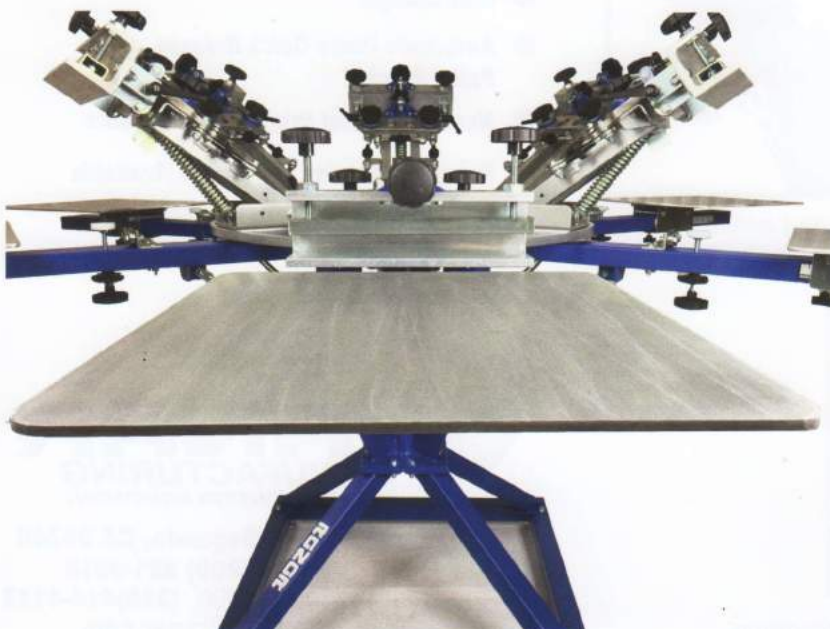

Station index